



Advance Metalpres Inc.
 Unit 120-2340 Viscount Way
 Richmond, BC, Canada
 V6V 1N1
 Tel: (604) 279-8266
 Fax: (604) 279-8265

Tank Model	Tank Capacity US Gal.	Shipping Weight LBS.	Tank Height Z in.	Diameter W in.	Recirc. Inlet - M in.	Recirc. Outlet - N in.
J 40 ST/SE	40	105	42 ½	21 ¼	14 ¼	8 ¼
J 60 ST/SE	60	137	62 ½	21 ¼	14 ¼	8 ¼
J 80 ST/SE	80	240	66 ½	23	15 ¾	9 ½
J 120 ST/SE	119	300	70 ½	27	15 ¾	9 ½



Maximum Operating Pressure 150 psi

Connections:

Model	40 & 60	80	120
A Hot Water Outlet	3/4" NPT nipple	1" NPT nipple	2" NPT nipple
B Cold Water Inlet	3/4" NPT nipple	1" NPT coupling	1 1/4" nipple
C Redirc. In	1 ¼" NPT coupling	2" NPT coupling	2" NPT coupling
D Redirc. Out	1 ¼" NPT coupling	2" NPT coupling	2" NPT coupling
E Aquastat	1/2" NPT coupling	1/2" NPT coupling	1/2" NPT coupling
F Temp. Gauge	Surface mount		
G Relief Connect	3/4" NPT coupling	3/4" NPT coupling	3/4" NPT coupling
H Drain	3/4" NPT coupling	3/4" NPT coupling	N/A

The method of using **Indirect Fired Hot Water Tanks** has become increasingly popular world wide. The combination of **efficiency** and **high recovery rate** provided by the **J Series Indirect Hot Water Tank** and **Storage Tanks** rewards the user with both **energy savings** and comfort of uninterrupted hot water usage. Storage tanks are ideal for commercial, industrial and residential applications that require a large demand for Domestic Hot Water. Ideally used in conjunction with our tankless coil **Double Wall heat exchanger**

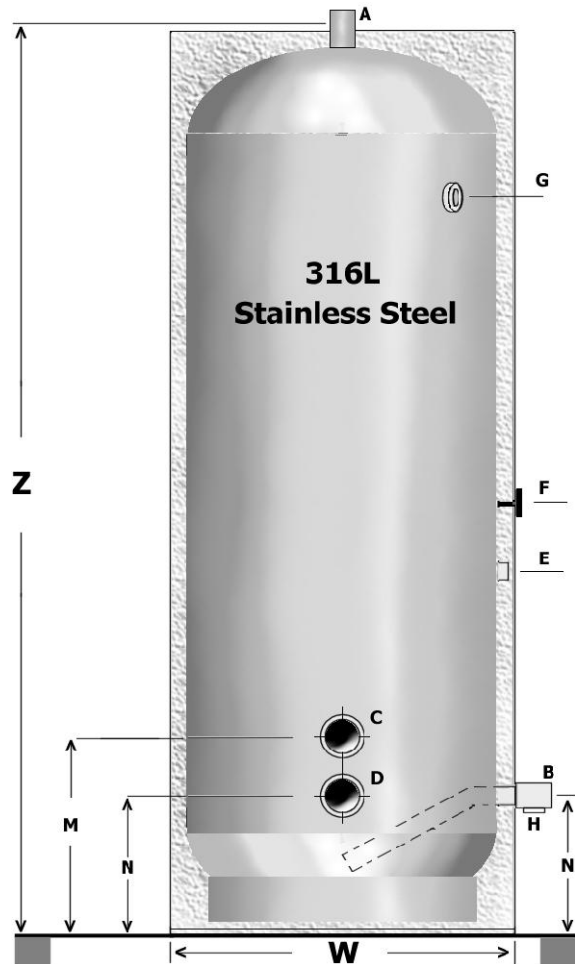

The J Series Tank Features:

Complete package with Aquastat, Temperature Gauge, Temp-Pressure Relief Valve and Drain Valve **drain not supplied with J120
 100% High Quality 316L Stainless Steel Construction

High Capacity storage for commercial and industrial applications

Designed for quick and simple installation

Powder coated steel jacket for high quality finish and durability

Non toxic fibreglass insulation

** Passivated Treatment for Maximum Corrosion Resistance. **

LIMITED WARRANTY
15 YEARS RESIDENTIAL
5 YEAR COMMERCIAL